

Write your name here

Surname

Other names

Centre Number

Candidate Number

Pearson Edexcel

Level 1/Level 2 GCSE (9 - 1)

Mathematics

Paper 2 (Calculator)

Higher Tier

Mock Set 1 – Autumn 2016

Time: 1 hour 30 minutes

Paper Reference

1MA1/2H

You must have: Ruler graduated in centimetres and millimetres, protractor, pair of compasses, pen, HB pencil, eraser, calculator. Tracing paper may be used.

Total Marks

Instructions

- Use **black** ink or ball-point pen.
- **Fill in the boxes** at the top of this page with your name, centre number and candidate number.
- Answer ALL questions.
- Answer the questions in the spaces provided – *there may be more space than you need.*
- **Calculators may be used.**
- If your calculator does not have a π button, take the value of π to be 3.142 unless the question instructs otherwise.
- Diagrams are **NOT** accurately drawn, unless otherwise indicated.
- You must **show all your working out.**



Information

- The total mark for this paper is 80.
- The marks for **each** question are shown in brackets – *use this as a guide as to how much time to spend on each question.*

Advice

- Read each question carefully before you start to answer it.
- Keep an eye on the time.
- Try to answer every question.
- Check your answers if you have time at the end.

Answer ALL questions.

Write your answers in the spaces provided.

You must write down all the stages in your working.

1 There are 60 students at a college.

20 students study both French and Spanish.

13 students study French but not Spanish.

A total of 43 students study Spanish.

(a) Complete the Venn diagram for this information.

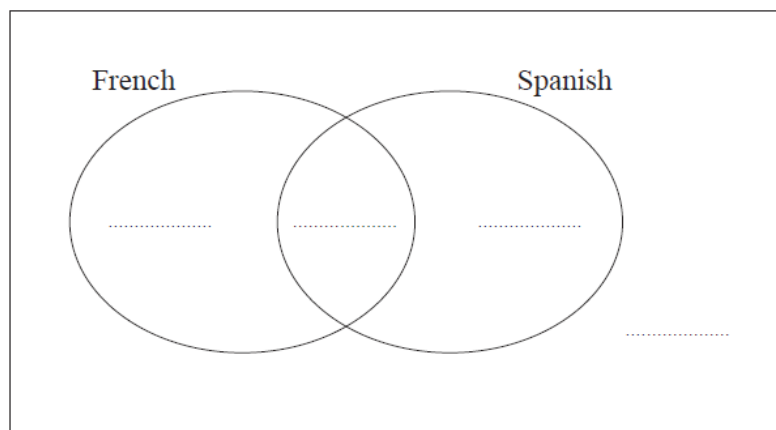

(3)

One of the students at the college is to be selected at random.

(b) Write down the probability that this student studies neither French nor Spanish.

.....

(1)

(Total for Question 1 is 4 marks)

2

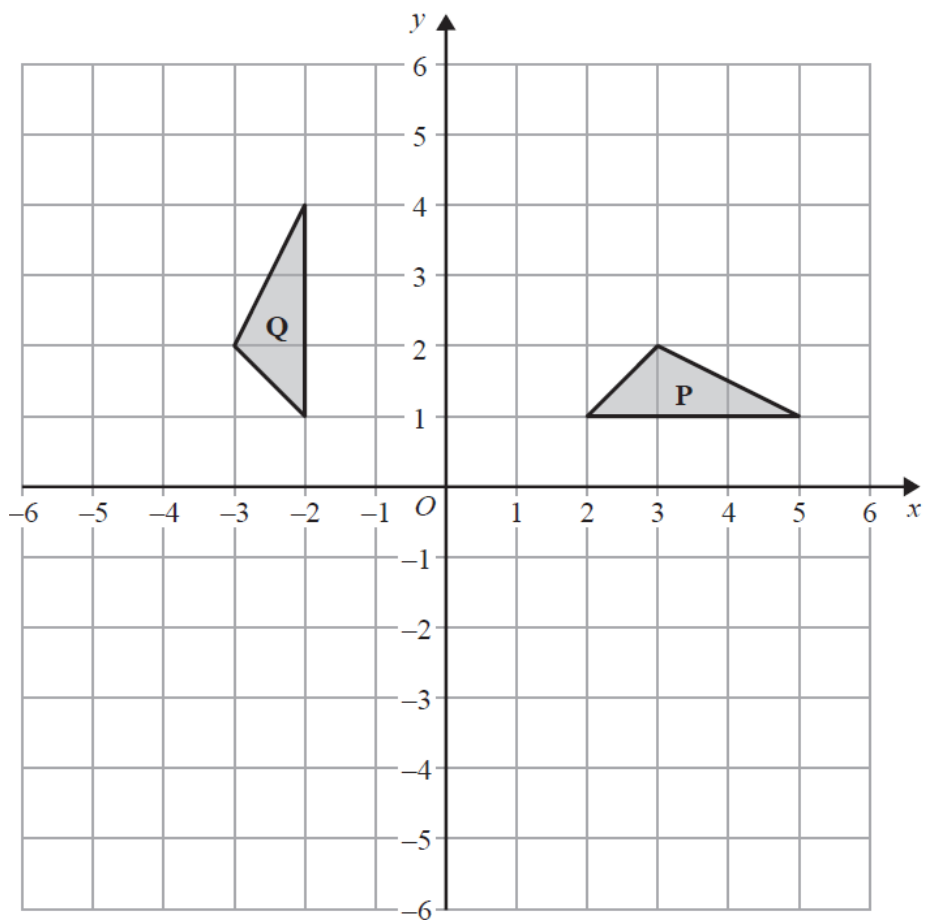

Describe fully the single transformation that maps triangle **P** onto triangle **Q**.

.....
.....

(Total for Question 2 is 2 marks)

- 3 Jean records the maximum daily temperature each day for 10 days. She also records the number of children going to a paddling pool for each of these days. She draws this scatter graph for her information.

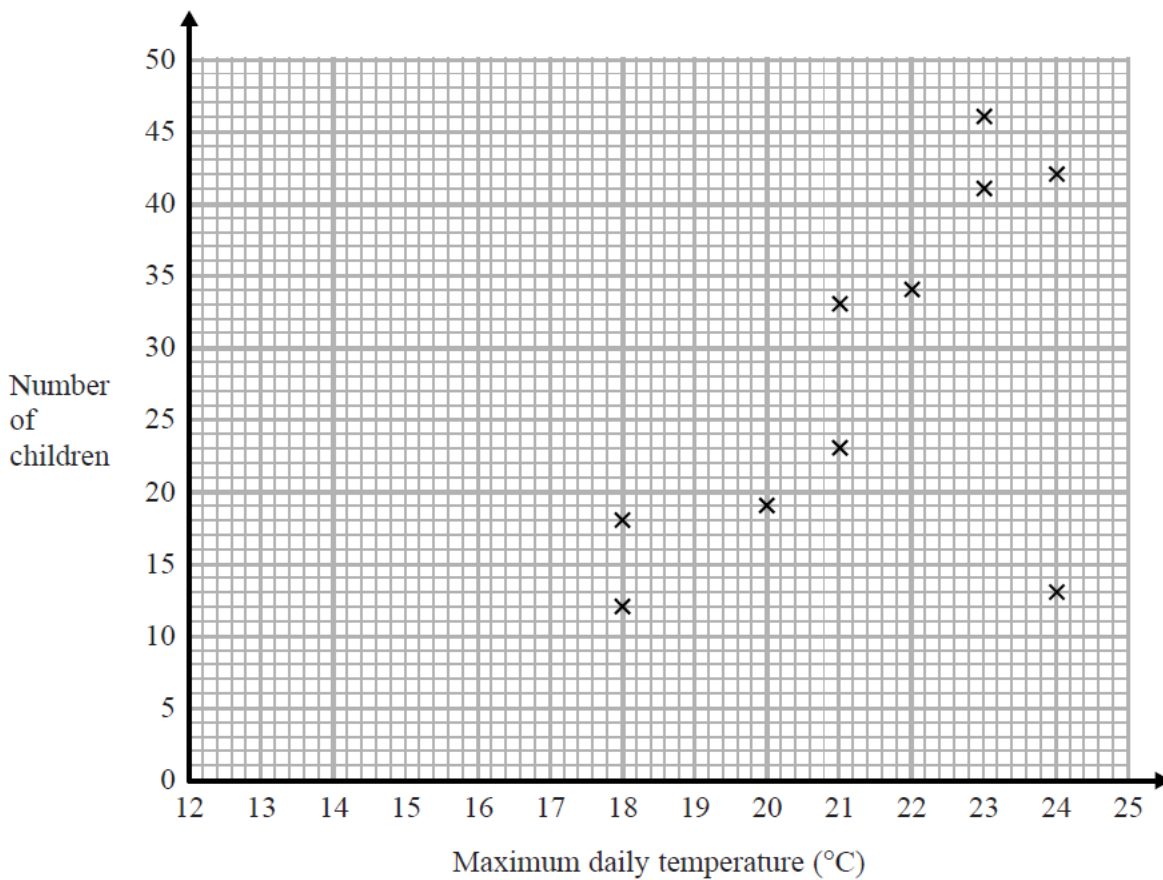

Jean's information for one of these days is an outlier on the scatter graph.

- (a) Give a possible reason for this.

.....

(1)

- (b) What type of correlation does the scatter graph show?

.....

(1)

On the 11th day, the maximum daily temperature was 19 °C.

- (c) Write down an estimate for the number of children going to the paddling pool on the 11th day.

.....

(1)

It would not be sensible to use the scatter graph to predict the number of children going to the paddling pool on a day when the maximum daily temperature was 13°C.

- (d) Give a reason why.

.....

.....

(1)

(Total for Question 3 is 4 marks)

4 The diagram shows a shape $ABCDEF$.

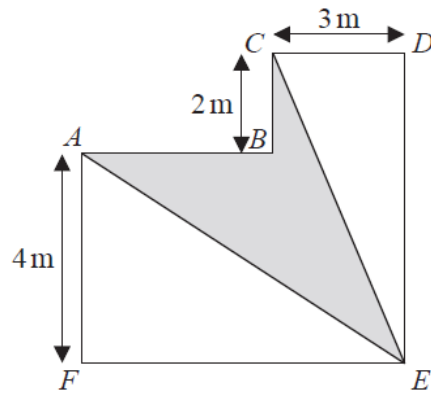

All the corners of the shape are right angles.
The perimeter of the shape is 28 m.

Work out the area of $ABCE$ shown shaded on the diagram.

.....
(Total for Question 4 is 5 marks)

5 Solve the simultaneous equations

$$4x + y = 10$$

$$x - 5y = 13$$

$x =$

$y =$

(Total for Question 5 is 3 marks)

- 6 (a) Complete the table of values for $y = \frac{3}{x}$

x	0.5	1	2	3	4	5	6
y		3	1.5		0.75		

(2)

- (b) On the grid, draw the graph of $y = \frac{3}{x}$ for values of x from 0.5 to 6

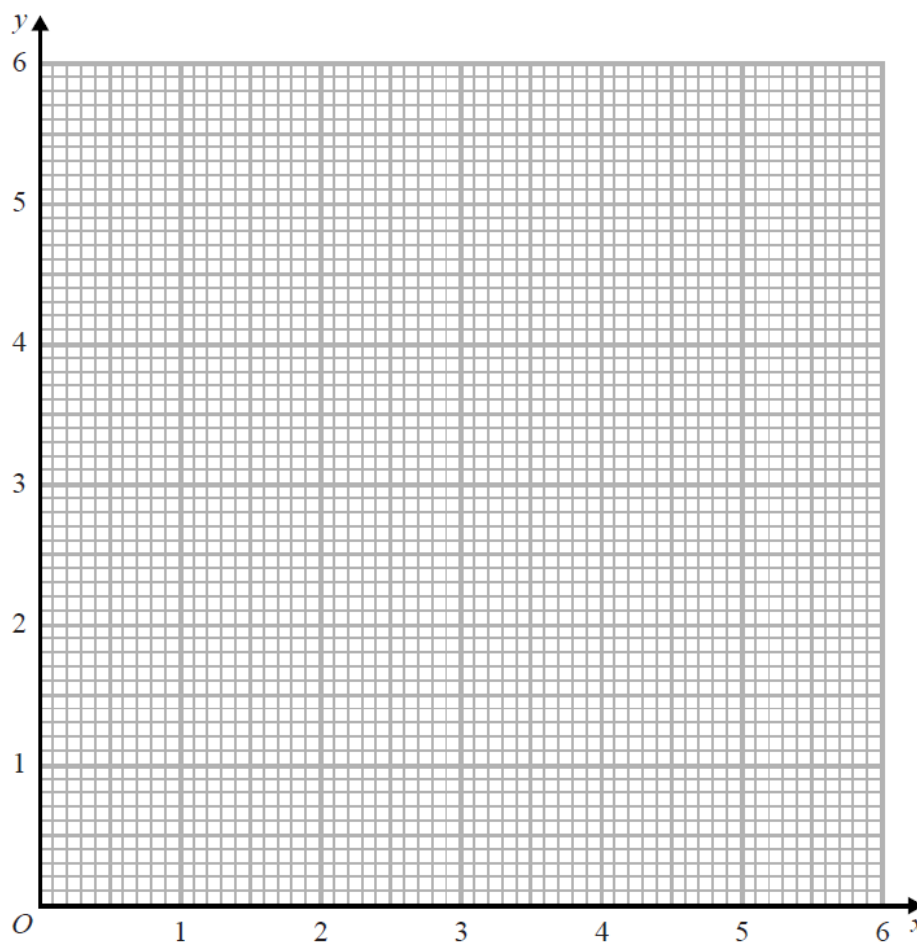

(2)

(Total for Question 6 is 4 marks)

7 Gina finds out the price of a CD box set in three different countries.

The price is

- £98 in the UK
- \$134.99 in the USA
- €139.99 in Germany

The exchange rates are

- £1 = \$1.43
- €1 = £0.73

Gina wants to pay the cheapest price for the box set.

- (a) From which country should Gina buy the box set?
You must show how you get your answer.

(3)

Gina lives in the UK.

- (b) Why might your answer to (a) **not** be the best country for Gina to buy the box set from?

.....

(1)

(Total for Question 7 is 4 marks)

8 Given that $a : b = 8 : 5$ and $b : c = 3 : 4$

find the ratio $a : b : c$

Give your answer in its simplest form.

.....

(Total for Question 8 is 3 marks)

9 (a) Write 3.6×10^4 as an ordinary number.

.....
(1)

(b) Work out the value of $(2.8 \times 10^{-2}) \div (4.7 \times 10^5)$
Give your answer in standard form correct to 3 significant figures.

.....
(2)

(Total for Question 9 is 3 marks)

10 The table shows pairs of values of x and y

x	5	6
y	400	576

(i) Tick the correct statement below.

$y \propto x$

$y \propto x^2$

$y \propto x^3$

(ii) Write a formula for y in terms of x

.....
(Total for Question 10 is 4 marks)

- 11 The bottom of a ladder is on horizontal ground.
The top of the ladder is leaning against a vertical wall.

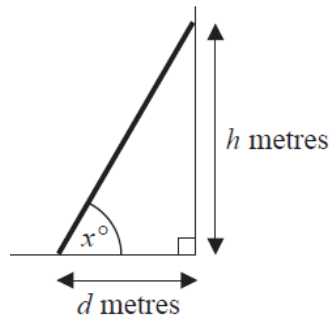

The bottom of the ladder is d metres from the wall.
The top of the ladder is h metres above the ground.
The angle between the ladder and the ground is x°

Some safety instructions say it is safe to climb the ladder when

$$h = 4d$$

- (a) Work out the value of x when $h = 4d$

.....

(3)

Some different safety instructions say the angle between the ladder and the ground should be 75°

The ladder is moved so that $x = 75$

- (b) How does this affect the height, h metres, of the top of the ladder above the ground?

.....

(1)

(Total for Question 11 is 4 marks)

12 Here are the first four terms of a quadratic sequence.

3 8 15 24

(a) Find an expression, in terms of n , for the n th term of this sequence.

.....
(3)

The n th term of a different sequence is $2^n + 5$

(b) Show that 36 is **not** a term of this sequence.

.....
.....
(1)

(Total for Question 12 is 4 marks)

13 Alex wants to find out how many ducks there are in a park.

One day he puts a tag on each of 30 of the ducks.

The next day he catches 40 ducks.

8 of these ducks have tags on them.

(i) Work out an estimate for the number of ducks in the park.

.....

Alex assumed that none of the tags fell off during the night.

(ii) If Alex's assumption is wrong, explain how this could affect your answer to part (i).

.....

.....

(Total for Question 13 is 4 marks)

14 Given that $3^{-n} = 0.2$

find the value of $(3^4)^n$

.....

(Total for Question 14 is 2 marks)

15

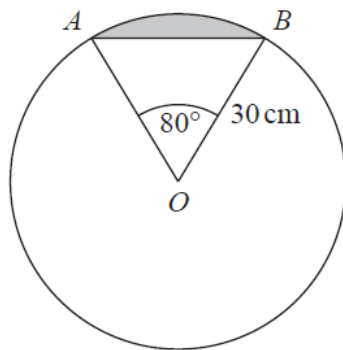

AB is a chord of a circle centre O .

The radius of the circle is 30 cm.

Angle $AOB = 80^\circ$

Work out what percentage of the area of the circle is shaded.

.....%

(Total for Question 15 is 5 marks)

16 For her maths homework, Helen answered the following question.

Shade the region that is defined by all these inequalities.

$$x + y \leq 6$$

$$y \geq 0$$

$$y \leq x + 2$$

Here is Helen's answer.

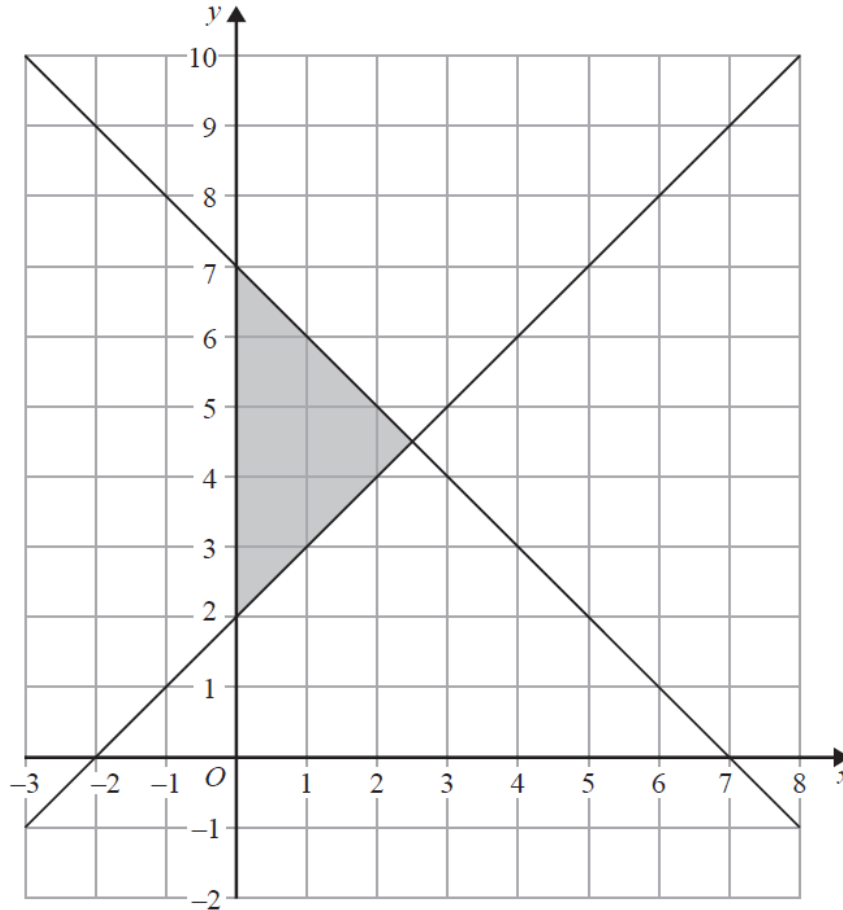

Helen made some mistakes when she answered the question.

Write down two mistakes Helen made.

1.....

2.....

(Total for Question 16 is 2 marks)

- 17 Here is a speed-time graph showing the speed, in metres per second, of an object t seconds after it started to move.

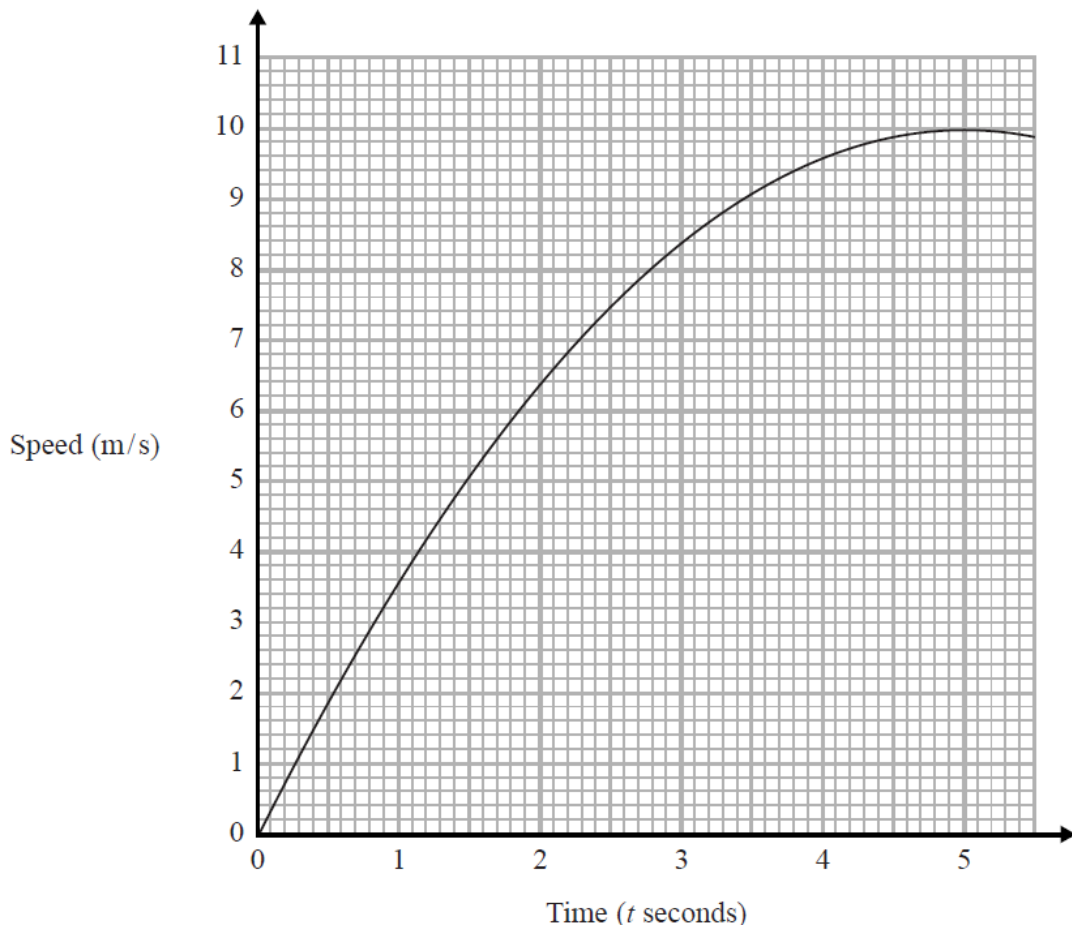

- (a) Use 3 strips of equal width to find an estimate for the area under the graph between $t = 1$ and $t = 4$

.....
(3)

(b) Describe fully what your answer to part (a) represents.

.....
.....

(2)

(c) Explain whether your answer in part (a) gives an underestimate or an overestimate for the area under the graph.

.....
.....

(1)

(Total for Question 17 is 6 marks)

18 There are 95 girls and 87 boys in Year 13 at a school.

One girl is going to be chosen for the role of Head Girl.
A different girl is going to be chosen for the role of Deputy Head Girl.
One boy is going to be chosen for the role of Head Boy.
A different boy is going to be chosen for the role of Deputy Head Boy.

Work out how many different ways this can be done.

.....
(Total for Question 18 is 3 marks)

- 19** P has coordinates $(-9, 7)$
 Q has coordinates $(11, 12)$

M is the point on the line segment PQ such that $PM : MQ = 2 : 3$

Line L is perpendicular to the line segment PQ .

L passes through M .

Find an equation of L .

.....
(Total for Question 19 is 5 marks)

20 Here is a sketch of part of the graph of $y = pq^x$ where $q > 0$

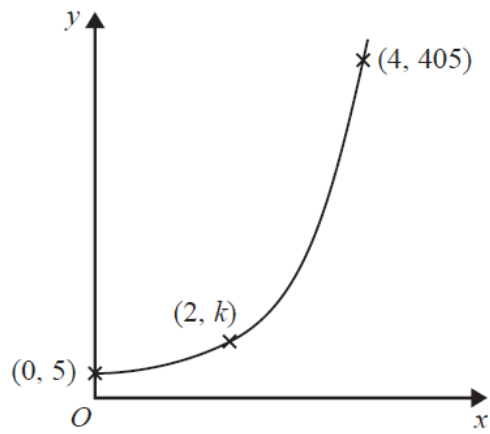

The points $(0, 5)$, $(2, k)$ and $(4, 405)$ are all on the graph of $y = pq^x$

Find the value of k .

.....
(Total for Question 20 is 4 marks)

21

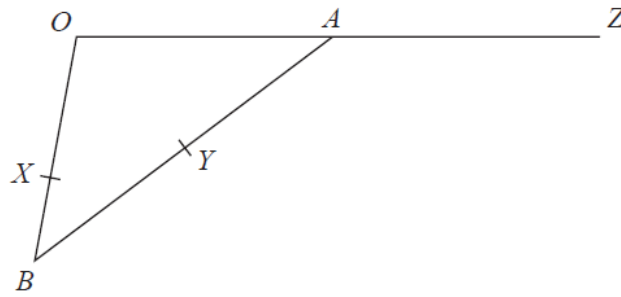

OAB is a triangle.

A is the midpoint of OZ

Y is the midpoint of AB

X is a point on OB

$$\vec{OA} = \mathbf{a} \quad \vec{OX} = 2\mathbf{b} \quad \vec{XB} = \mathbf{b}$$

Prove that XYZ is a straight line.

(Total for Question 21 is 5 marks)

TOTAL FOR PAPER: 80 MARKS